

## » SFK02+ FR (LCD) RS485 BACnet

Immersion temperature sensor

**thermokon**<sup>®</sup>  
HOME OF SENSOR TECHNOLOGY

### Datasheet

Subject to technical alteration  
Issue date: 16.05.2019 • A100



### » APPLICATION

Duct/Immersion sensor for measurement of air temperature and other gaseous mediums for HVAC applications (e.g. supply and exhaust ducts) with pocket  $\varnothing=6$  mm. LCD models with RGB background light have a transparent cover. Display configuration and threshold values for color changes can be parameterized via Thermokon USEapp. With the option board relay two-point controllers or a 2-stage 2-point controller for temperature can be realized. Can be used as an immersion temperature sensor combined with a thermowell pocket.

### » TYPES AVAILABLE

Immersion sensor temperature optional with display – active RS485 BACnet MS/TP

SFK02+ FR (LCD) RS485 BACnet 050.04  
SFK02+ FR (LCD) RS485 BACnet 100.06/04  
SFK02+ FR (LCD) RS485 BACnet 200.06/04

Optional mounting length 50/100/200/300 mm

### » SECURITY ADVICE – CAUTION



The installation and assembly of electrical equipment should only be performed by authorized personnel.

The product should only be used for the intended application. Unauthorised modifications are prohibited! The product must not be used in relation with any equipment that in case of a failure may threaten, directly or indirectly, human health or life or result in danger to human beings, animals or assets. Ensure all power is disconnected before installing. Do not connect to live/operating equipment.

Please comply with

- Local laws, health & safety regulations, technical standards and regulations
- Condition of the device at the time of installation, to ensure safe installation
- This data sheet and installation manual

## » NOTES ON DISPOSAL



As a component of a large-scale fixed installation, Thermokon products are intended to be used permanently as part of a building or a structure at a pre-defined and dedicated location, hence the Waste Electrical and Electronic Act (WEEE) is not applicable. However, most of the products may contain valuable materials that should be recycled and not disposed of as domestic waste. Please note the relevant regulations for local disposal.

## » BUILD-UP OF SELF-HEATING BY ELECTRICAL DISSIPATIVE POWER

Temperature sensors with electronic components always have a dissipative power, which affects the temperature measurement of the ambient air. The dissipation in active temperature sensors shows a linear increase with rising operating voltage. This dissipative power has to be considered when measuring temperature. In case of a fixed operating voltage ( $\pm 0,2$  V) this is normally done by adding or reducing a constant offset value. As Thermokon transducers work with a variable operating voltage, only one operating voltage can be taken into consideration, for reasons of production engineering. Transducers 0..10 V / 4..20 mA have a standard setting at an operating voltage of 24 V =. That means, that at this voltage, the expected measuring error of the output signal will be the least. For other operating voltages, the offset error will be increased by a changing power loss of the sensor electronics. If a re-calibration should become necessary later directly on the sensor, this can be done by means of the USEapp software and an optional Bluetooth interface.

**Remark: Occurring draft leads to a better carrying-off of dissipative power at the sensor. Thus temporally limited fluctuations might occur upon temperature measurement.**

## » TECHNICAL DATA

Measuring values	temperature		
Output voltage	0..10 V or 0..5 V, min load 10k $\Omega$ (live-zero configuration via Thermokon USEapp)		
Network technology	RS485 BACnet MS/TP		
Power supply	15..35 V = or 19..29 V ~		
Power consumption	max. 2,3 W (24 V =)   max. 4,3 VA (24 V ~)		
Output signal range temp. *Scaling analogue output	-20..+80 °C (default setting), selectable from 8 temperature ranges -50..+50   -20..+80   -15..+35   -10..+120   0..+50   0..+100   0..+160   0..+250 °C, optionally configurable via Thermokon USEapp		
Operating temperature range * Max. permissible operating temperature	sensor pocket -50..+160 °C	electronic   enclosure with LCD -20..+70 °C	electronic   enclosure without LCD -35..+70 °C
Accuracy temperature	$\pm 0,5$ K (typ. at 21 °C), time constant: $T_{63\%}$ 2,5 s		
Display *optional	LCD 29x35 mm with RGB backlight		
Enclosure	enclosure USE-M, PC, pure white, cover PC, transparent, with removable cable entry		
Protection	IP65 according to EN 60529		
Cable entry	M25, for wire max. $\varnothing=7$ mm, seal insert for fourfold cable entry		
Connection electrical	Mainboard removable plug-in terminal, max. 2,5 mm <sup>2</sup>	Plug-in card removable plug-in terminal, max. 1,5 mm <sup>2</sup>	
Pocket	stainless steel V4A, $\varnothing=6$   4 mm, mounting length: 50   100   200   300 mm, thread R 1/2" max. operating pressure 10 bar (145psi)		
Ambient condition	max. 85% rH short term condensation		

## » PRODUCT TESTING AND CERTIFICATION



Declaration of conformity

The declaration of conformity of the products can be found on our website <https://www.thermokon.de/>.

## » USE ENCLOSURE WITH UV AND WEATHER RESISTANCE

After some time, outdoor mounted plastics can lose their color and quality. Therefore, all USE housings are made of special white polycarbonate (PC). The light-stable colorants and additives are used to achieve optimum protection of the polymer while maintaining color stability. The titanium dioxide used is specially developed for polycarbonate and offers excellent UV protection through the reflection of the entire light spectrum including the UV component by 340 nm. This effectively counteracts the otherwise occurring photochemical polymer degradation. The colors stay full for a long time without fading. The material is also resistant to cold and frost.

» CONFIGURATION



The Thermokon bluetooth dongle with micro-USB is required for communication between USEapp and USE-M / USE L (Item No.: 668262). Commercial bluetooth dongles are not compatible.

Application-specific reconfiguration of the devices can be carried out using the Thermokon USEapp. The configuration is carried out in the voltage-supplied state.

The configuration-app and the app description can be found in the Google Play Store or in the Apple App Store.

» APPLICATION NOTICE



The housing cover must be completely closed in order to ensure the accuracy and reproducibility of the measured values during a test or service log via USEapp.

The Bluetooth dongle snaps into the socket easily. When removing, please fix the plug-in card (option PCB) so that it is not unintentionally pulled out.

» CONNECTION PLAN

To change the output voltage range (default 0..10 V to 0..5 V) via jumper, the display must be removed from the board first. If the RS485 cable is looped through, connect both cable shields using the enclosed 2-pol. Connect terminal as shown.

SFK02+ FR (LCD) RS485 BACnet

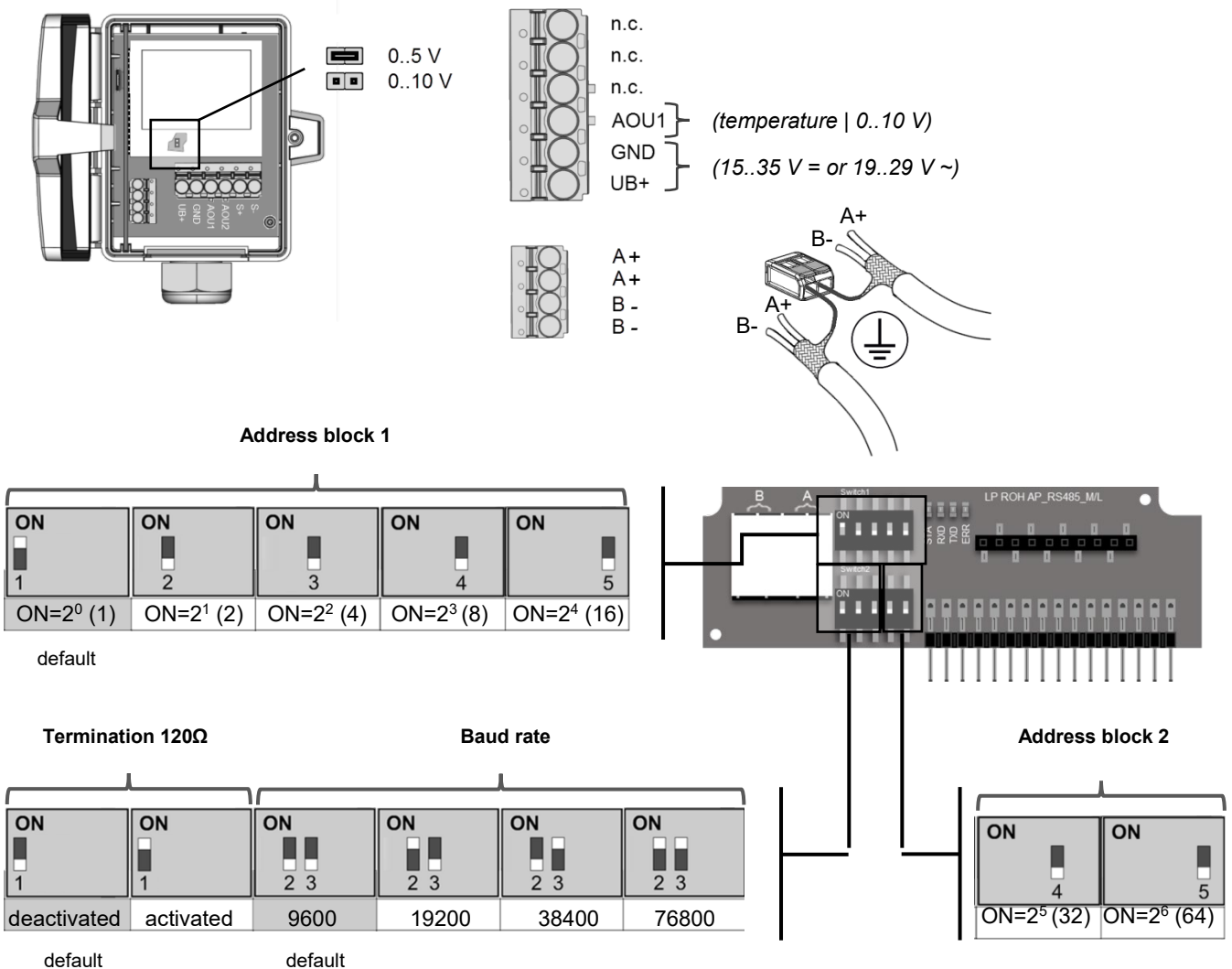

## » MEASURING VALUES

Objects	Access	Description	Unit
AI-0	R	temperature	°C

The BACnet address of the device is set binary coded in the range of 1 ... 127 via 7 dip-switches. (the address 0 is reserved and cannot be selected).



**BACnet Objects:**  
USE-RS485 BACnet interface

A detailed description of the BACnet interface can be found at the following link:

→ [Download](#)

## » DIMENSIONS (MM)

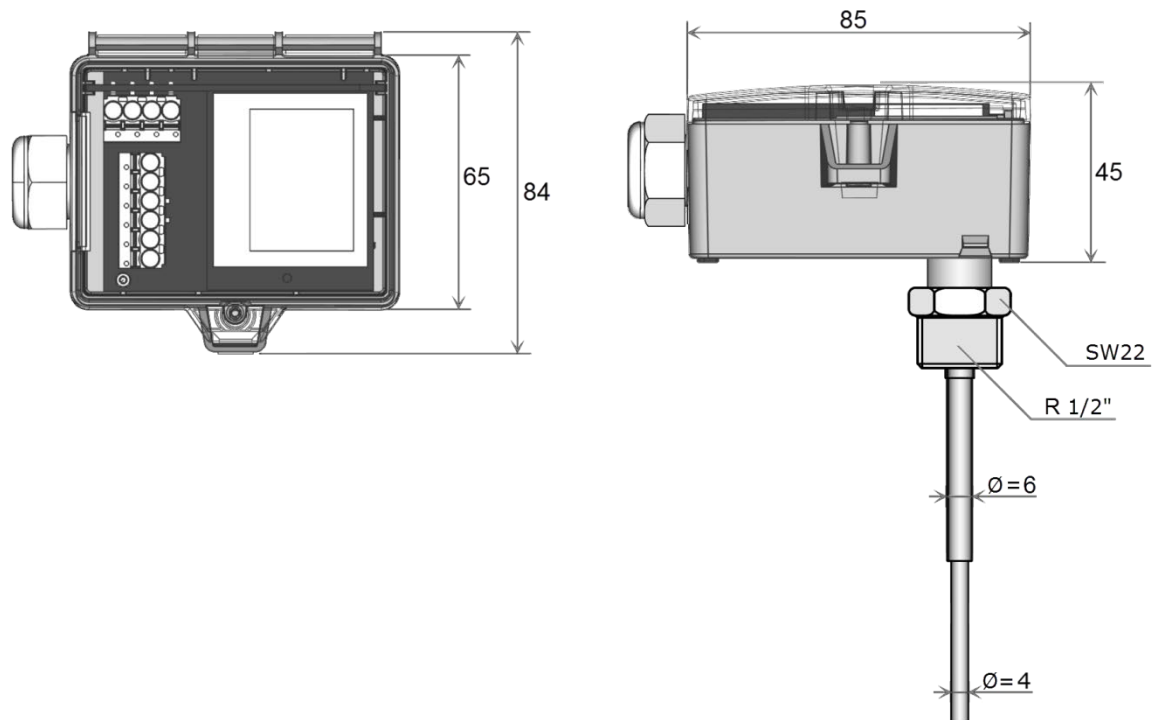

## » ACCESSORIES (INCLUDED IN DELIVERY)

Mounting kit universal

• Cover screw + screw cover • 2 Rawlplugs • 2 Screws (countersunk head) • 2 Screws (rounded head)

Item No. 698511

## » ACCESSORIES (OPTIONAL)

Bluetooth dongle

Item No. 668262